

# Multistage Horizontal High-pressure Centrifugal Pump

Installation/Operating Manual  
**DPH(S)I**

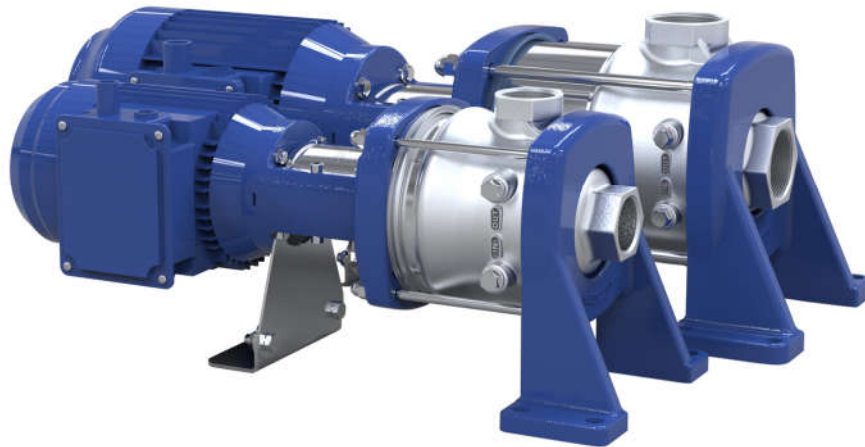

## **Legal information/Copyright**

Original operating manual DPH(S)I

All rights reserved. The contents provided herein must neither be distributed, copied, reproduced, edited or processed for any other purpose, nor otherwise transmitted, published or made available to a third party without the manufacturer's express written consent.

Subject to technical modification without prior notice.

© D.P. Industries B.V., Alphen aan den Rijn, Nederland

# Contents

	<b>Glossary.....</b>	<b>5</b>
<b>1</b>	<b>General.....</b>	<b>6</b>
	1.1 Principles .....	6
	1.2 Installation of partly completed machinery.....	6
	1.3 Target group .....	6
	1.4 Other applicable documents .....	6
	1.5 Symbols .....	7
<b>2</b>	<b>Safety .....</b>	<b>8</b>
	2.1 Key to safety symbols/markings .....	8
	2.2 General .....	8
	2.3 Intended use .....	8
	2.4 Personnel qualification and training.....	9
	2.5 Consequences and risks caused by non-compliance with this manual .....	9
	2.6 Safety awareness .....	10
	2.7 Safety information for the operator/user .....	10
	2.8 Safety information for maintenance, inspection and installation.....	10
	2.9 Unauthorised modes of operation.....	10
<b>3</b>	<b>Transport/Temporary Storage/Disposal .....</b>	<b>11</b>
	3.1 Checking the condition upon delivery .....	11
	3.2 Transport.....	11
	3.3 Storage/preservation .....	12
	3.4 Disposal .....	13
	3.5 Return to supplier .....	13
<b>4</b>	<b>Description of the Pump (Set) .....</b>	<b>14</b>
	4.1 General description.....	14
	4.2 Designation .....	14
	4.3 Name plate .....	15
	4.4 Design details .....	15
	4.5 Configuration and function.....	16
	4.6 Noise characteristics.....	17
	4.7 Scope of supply .....	17
	4.8 Dimensions and weights.....	17
<b>5</b>	<b>Installation at Site .....</b>	<b>18</b>
	5.1 Safety regulations .....	18
	5.2 Checks to be carried out prior to installation.....	18
	5.3 Installing the pump set.....	18
	5.4 Piping.....	19
	5.4.1 Connecting the piping.....	19
	5.4.2 Permissible forces and moments at the pump nozzles .....	21
	5.5 Fitting a bypass .....	21
	5.6 Electrical connection.....	21
	5.7 Checking the direction of rotation .....	23
<b>6</b>	<b>Commissioning/Start-up/Shutdown .....</b>	<b>25</b>
	6.1 Commissioning/Start-up .....	25
	6.1.1 Prerequisites for commissioning/start-up .....	25
	6.1.2 Priming and venting the pump.....	25
	6.2 Operating limits .....	28
	6.2.1 Minimum flow rate and maximum flow rate .....	29
	6.2.2 Pressure limits and temperature limits .....	29
	6.2.3 Rated current and maximum current.....	30
	6.3 Shutdown/storage/preservation .....	30
	6.3.1 Measures to be taken for shutdown .....	30



6.4	Returning to service.....	31
<b>7</b>	<b>Servicing/Maintenance .....</b>	<b>32</b>
7.1	Safety regulations .....	32
7.2	Servicing/inspection.....	33
7.2.1	Supervision of operation.....	33
7.2.2	Lubrication and lubricant change .....	34
7.3	Drainage/cleaning.....	35
7.4	Dismantling the pump set .....	36
7.4.1	General information/Safety regulations .....	36
7.4.2	Preparing the pump set.....	37
7.4.3	Removing the motor .....	37
7.4.4	Removing the retaining bracket (optional).....	38
7.4.5	Removing the mechanical seal .....	38
7.5	Reassembling the pump set .....	40
7.5.1	General information/Safety regulations .....	40
7.5.2	Installing the mechanical seal .....	40
7.5.3	Mounting the motor .....	42
7.5.4	Adjusting the mechanical seal, coupling and pump shaft.....	44
7.6	Tightening torques .....	46
7.7	Spare parts stock.....	46
7.7.1	Ordering spare parts .....	46
<b>8</b>	<b>Trouble-shooting .....</b>	<b>47</b>
<b>9</b>	<b>Related Documents .....</b>	<b>49</b>
9.1	General assembly drawings/exploded views with list of components .....	49
9.1.1	DPH(S)I .....	49
9.1.2	Motor .....	50
9.2	Wiring diagram.....	51
<b>10</b>	<b>EU Declaration of Conformity.....</b>	<b>52</b>
<b>11</b>	<b>Certificate of Decontamination.....</b>	<b>53</b>
	<b>Index.....</b>	<b>54</b>

# Glossary

## **Certificate of decontamination**

---

A certificate of decontamination is enclosed by the customer when returning the product to the manufacturer to certify that the product has been properly drained to eliminate any environmental and health hazards arising from components in contact with the fluid handled.

## **Discharge line**

---

The pipeline which is connected to the discharge nozzle

## **Hydraulic system**

---

The part of the pump in which the kinetic energy is converted into pressure energy

## **IE3**

---

Efficiency class to IEC 60034-30: 3 = Premium Efficiency (IE = International Efficiency)

## **Noise characteristics**

---

The noise characteristics are indicated as surface sound pressure level in dB(A).

## **Pump**

---

Machine without drive, additional components or accessories

## **Pump set**

---

Complete pump set consisting of pump, drive, additional components and accessories

## **Suction lift line/suction head line**

---

The pipeline which is connected to the suction nozzle



---

# 1 General

## 1.1 Principles

This operating manual is supplied as an integral part of the type series and variants indicated on the front cover. The manual describes the proper and safe use of this equipment in all phases of operation.

The name plate indicates the type series, the main operating data and the serial number. The serial number uniquely describes the product and is used as identification in all further business processes.

In the event of damage, immediately contact your nearest DP service centre to maintain the right to claim under warranty.

Observe the noise characteristics, indicated as surface sound pressure level.  
[⇒ Section 4.6, Page 17]

## 1.2 Installation of partly completed machinery

To install partly completed machinery supplied by DP refer to the sub-sections under Servicing/Maintenance.

## 1.3 Target group

This operating manual is aimed at the target group of trained and qualified specialist technical personnel. [⇒ Section 2.4, Page 9]

## 1.4 Other applicable documents

Table 1: Overview of other applicable documents

Document	Contents
Data sheet	Description of the technical data of the pump (set)
General arrangement drawing/outline drawing	Description of mating and installation dimensions for the pump (set), weights
Drawing of auxiliary connections	Description of auxiliary connections
Hydraulic characteristic curve	Characteristic curves showing head, NPSH required, efficiency and power input
General assembly drawing <sup>1)</sup>	Sectional drawing of the pump
Sub-supplier product literature <sup>1)</sup>	Operating manuals and other product literature describing accessories and integrated machinery components
Spare parts lists <sup>1)</sup>	Description of spare parts
Piping layout <sup>1)</sup>	Description of auxiliary piping
List of components <sup>1)</sup>	Description of all pump components
Drawing for assembly <sup>1)</sup>	Sectional drawing of the installed shaft seal

For accessories and/or integrated machinery components observe the relevant manufacturer's product literature.

---

1) If agreed upon in scope of supply

## 1.5 Symbols

Table 2: Symbols used in this manual

Symbol	Description
✓	Conditions which need to be fulfilled before proceeding with the step-by-step instructions
▷	Safety instructions
⇒	Result of an action
⇒	Cross-references
1. 2.	Step-by-step instructions
	Note Recommendations and important information on how to handle the product







# 2 Safety



All the information contained in this section refers to hazardous situations.

## 2.1 Key to safety symbols/markings

Table 3: Definition of safety symbols/markings

Symbol	Description
	<b>DANGER</b> This signal word indicates a high-risk hazard which, if not avoided, will result in death or serious injury.
	<b>WARNING</b> This signal word indicates a medium-risk hazard which, if not avoided, could result in death or serious injury.
	<b>CAUTION</b> This signal word indicates a hazard which, if not avoided, could result in damage to the machine and its functions.
	<b>General hazard</b> In conjunction with one of the signal words this symbol indicates a hazard which will or could result in death or serious injury.
	<b>Electrical hazard</b> In conjunction with one of the signal words this symbol indicates a hazard involving electrical voltage and identifies information about protection against electrical voltage.
	<b>Machine damage</b> In conjunction with the signal word CAUTION this symbol indicates a hazard for the machine and its functions.

## 2.2 General

This operating manual contains general installation, operating and maintenance instructions that must be observed to ensure safe operation of the system and prevent personal injury and damage to property.

The safety information in all sections of this manual must be complied with.

The operating manual must be read and understood by the responsible specialist personnel/operators prior to installation and commissioning.

The contents of this operating manual must be available to the specialist personnel at the site at all times.

Information attached directly to the product must always be complied with and kept in a perfectly legible condition at all times. This applies to, for example:

- Arrow indicating the direction of rotation
- Markings for connections
- Name plate

The operator is responsible for ensuring compliance with all local regulations not taken into account in this operating manual.

## 2.3 Intended use

- The pump (set) must only be operated within the operating limits described in the other applicable documents. [⇒ Section 1.4, Page 6]
- Only operate pumps/pump sets which are in perfect technical condition.
- Do not operate the pump (set) in partially assembled condition.



- Only use the pump to handle the fluids described in the data sheet or product literature of the pump model or variant.
- Never operate the pump without the fluid to be handled.
- Observe the minimum flow rates indicated in the data sheet or product literature (to prevent overheating, bearing damage, etc).
- Observe the minimum flow rate and maximum flow rate indicated in the data sheet or product literature (to prevent overheating, mechanical seal damage, cavitation damage, bearing damage, etc).
- Do not throttle the flow rate on the suction side of the pump (to prevent cavitation damage).
- Consult the manufacturer about any use or mode of operation not described in the data sheet or product literature.

#### **Prevention of foreseeable misuse**

- Never open the discharge-side shut-off elements further than permitted.
  - The maximum flow rates specified in the product literature or data sheet would be exceeded.
  - Risk of cavitation damage
- Never exceed the permissible operating limits specified in the data sheet or product literature regarding pressure, temperature, etc.
- Observe all safety information and instructions in this manual.

## **2.4 Personnel qualification and training**

All personnel involved must be fully qualified to transport, install, operate, maintain and inspect the machinery this manual refers to.

The responsibilities, competence and supervision of all personnel involved in transport, installation, operation, maintenance and inspection must be clearly defined by the operator.

Deficits in knowledge must be rectified by means of training and instruction provided by sufficiently trained specialist personnel. If required, the operator can commission the manufacturer/supplier to train the personnel.

Training on the pump (set) must always be supervised by technical specialist personnel.

## **2.5 Consequences and risks caused by non-compliance with this manual**

- Non-compliance with these operating instructions will lead to forfeiture of warranty cover and of any and all rights to claims for damages.
- Non-compliance can, for example, have the following consequences:
  - Hazards to persons due to electrical, thermal, mechanical and chemical effects and explosions
  - Failure of important product functions
  - Failure of prescribed maintenance and servicing practices
  - Hazard to the environment due to leakage of hazardous substances

---

## 2.6 Safety awareness

In addition to the safety information contained in this manual and the intended use, the following safety regulations shall be complied with:

- Accident prevention, health regulations and safety regulations
- Explosion protection regulations
- Safety regulations for handling hazardous substances
- Applicable standards, directives and laws

## 2.7 Safety information for the operator/user

- The operator shall fit contact guards for hot, cold and moving parts and check that the guards function properly.
- Do not remove any contact guards during operation.
- Provide the personnel with protective equipment and make sure it is used.
- Contain leakages (e.g. at the shaft seal) of hazardous fluids handled (e.g. explosive, toxic, hot) so as to avoid any danger to persons and the environment. Adhere to all relevant laws.
- Eliminate all electrical hazards. (In this respect refer to the applicable national safety regulations and/or regulations issued by the local energy supply companies.)
- If shutting down the pump does not increase potential risk, fit an emergency-stop control device in the immediate vicinity of the pump (set) during pump set installation.

## 2.8 Safety information for maintenance, inspection and installation

- Modifications or alterations of the pump are only permitted with the manufacturer's prior consent.
- Use only original spare parts or parts authorised by the manufacturer. The use of other parts can invalidate any liability of the manufacturer for resulting damage.
- The operator ensures that maintenance, inspection and installation is performed by authorised, qualified specialist personnel who are thoroughly familiar with the manual.
- Only carry out work on the pump (set) during standstill of the pump.
- Only perform work on the pump set when it has been disconnected from the power supply (de-energised).
- The pump casing must have cooled down to ambient temperature.
- Pump pressure must have been released and the pump must have been drained.
- When taking the pump set out of service always adhere to the procedure described in the manual. [⇒ Section 6.3, Page 30]
- Decontaminate pumps which handle fluids posing a health hazard.
- As soon as the work has been completed, re-install and re-activate any safety-relevant devices and protective devices. Before returning the product to service, observe all instructions on commissioning. [⇒ Section 6.1, Page 25]

## 2.9 Unauthorised modes of operation

Never operate the pump (set) outside the limits stated in the data sheet and in this manual.

The warranty relating to the operating reliability and safety of the supplied pump (set) is only valid if the equipment is used in accordance with its intended use. [⇒ Section 2.3, Page 8]

# 3 Transport/Temporary Storage/ Disposal

## 3.1 Checking the condition upon delivery

1. On transfer of goods, check each packaging unit for damage.
2. In the event of in-transit damage, assess the exact damage, document it and notify DP or the supplying dealer and the insurer about the damage in writing immediately.

## 3.2 Transport

### Transporting the pump set



#### **⚠ DANGER**

##### **Improper transport**

Danger to life from falling parts!

Damage to the pump set!

- Use the attachment point provided for attaching the lifting accessory.
- Never suspend the pump set by its power cable.
- Use the lifting chain/rope included in the scope of supply exclusively for lowering or lifting the pump set into/out of the pump sump.
- Securely attach the lifting chain/rope to the pump and crane.
- Use tested, marked and approved lifting accessories only.
- Observe the regional transport regulations.
- Observe the product literature supplied by the lifting accessory manufacturer.
- The load-carrying capacity of the lifting accessory must be higher than the weight indicated on the name plate of the pump set to be lifted. Take into account any additional system components to be lifted.



#### **⚠ WARNING**

##### **Improper lifting/moving of heavy assemblies or components**

Personal injury and damage to property!

- Use suitable transport devices, lifting equipment and lifting tackle to move heavy assemblies or components.

To transport the pump/pump set suspend it from the lifting tackle as shown.

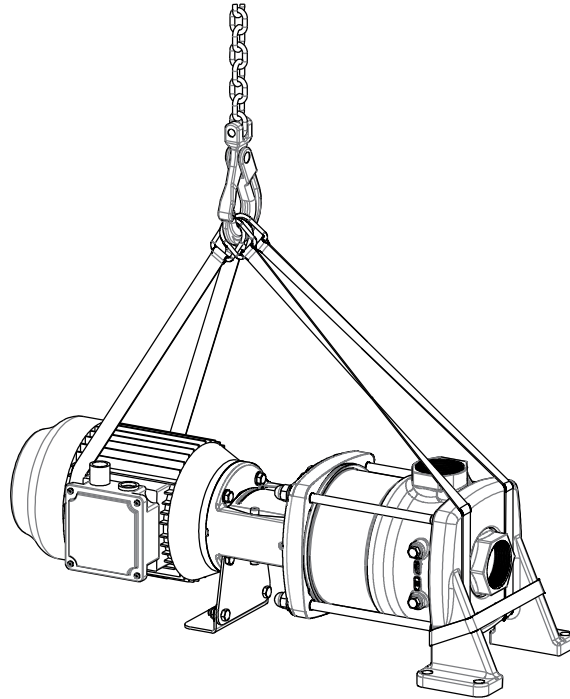

Fig. 1: Transporting the pump set

### Placing down the pump set



#### **WARNING**

##### **Incorrect positioning / incorrect placing down**

Personal injury and damage to property!

- Use appropriate means to secure the pump set against tilting and tipping over.
- Refer to the weights given in the data sheet/on the name plate.

### 3.3 Storage/preservation

If commissioning is to take place some time after delivery, take the following measures:



#### **CAUTION**

##### **Damage during storage due to humidity, dirt, or vermin**

Corrosion/contamination of the pump (set)!

- For outdoor storage cover the packed or unpacked pump (set) and accessories with waterproof material.

- Store the pump set in dry, vibration-free conditions and in its original packaging.
- Fill some antifreeze (e.g. ethylene glycol) into the pump to protect it from frost/freezing.
- Manually rotate the shaft once every three months as well as shortly before start-up.
- Spray the inside of the mechanical seal chamber with a preservative to prevent seizure of the mechanical seal.

Table 4: Ambient conditions for storage

Ambient condition	Value
Relative humidity	5 % to 80 % <sup>2)</sup> (non-condensing)
Ambient temperature	-10 °C to +40 °C <sup>3)</sup>

### 3.4 Disposal



#### **WARNING**

**Fluids handled, consumables and supplies which are hot and/or pose a health hazard**

Hazard to persons and the environment!

- Collect and properly dispose of flushing fluid and any fluid residues.
- Wear safety clothing and a protective mask if required.
- Observe all legal regulations on the disposal of fluids posing a health hazard.

1. Dismantle the pump (set).  
Collect greases and other lubricants during dismantling.
2. Separate and sort the pump materials, e.g. by:
  - Metals
  - Plastics
  - Electronic waste
  - Greases and other lubricants
3. Dispose of materials in accordance with local regulations or in another controlled manner.

### 3.5 Return to supplier

1. Drain the pump as per operating instructions.
2. Flush and clean the pump, particularly if it has been used for handling noxious, explosive, hot or other hazardous fluids.
3. If the pump has handled fluids whose residues could lead to corrosion damage in the presence of atmospheric humidity or could ignite upon contact with oxygen also neutralise the pump and blow through with anhydrous inert gas to ensure drying.
4. Always complete and enclose a certificate of decontamination when returning the pump. Indicate any safety measures and decontamination measures taken.  
[⇒ Section 11, Page 53]

2) At +20 °C

3) Optional: -10 °C to +55 °C

---

## 4 Description of the Pump (Set)

### 4.1 General description

- Multistage horizontal high-pressure centrifugal pump
- Pump for handling clean or slightly aggressive aqueous fluids.

### 4.2 Designation

**Example: DPH(S)I 4/2 B**

Table 5: Designation key

Code	Description	
DP	Type series	
HS	Design	
	H	Pump casing made of stainless steel 1.4308 Hydraulic system of the pump made of stainless steel 1.4301
	HS	Pump casing made of stainless steel 1.4408 Hydraulic system of the pump made of stainless steel 1.4404
I	Type of connection	
	I	Internal thread
4	Size, flow rate [m <sup>3</sup> /h] at BEP	
	2, 4, 6, 10, 15	
2	Number of stages	
-	Number of stages with a special impeller	
	- <sup>4)</sup>	No stage with a special impeller
	-L	One stage with a special impeller for lower NPSH values
B	Generation	

## 4.3 Name plate

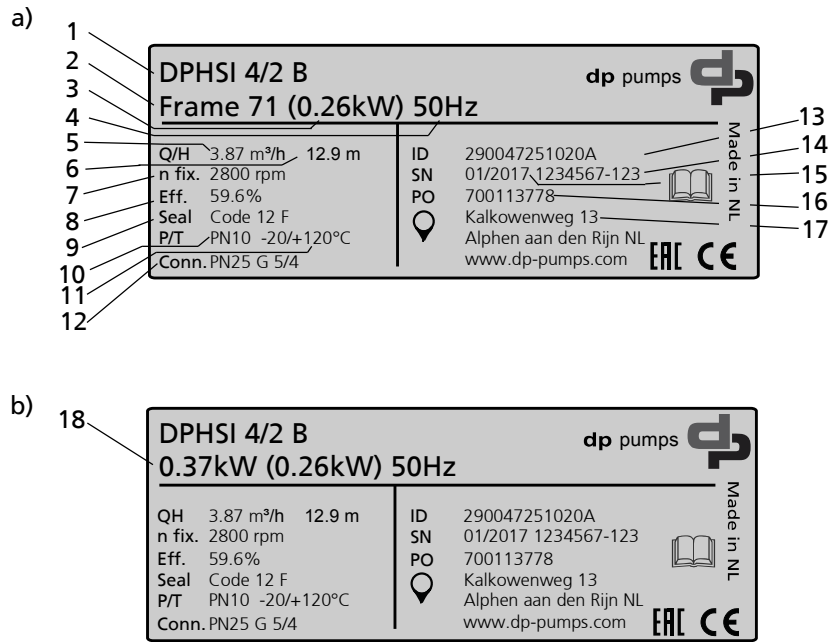

Fig. 2: Name plate (example) a) Pump without motor b) Pump with motor

1	Designation	2	Frame size
3	Power required	4	Rated frequency
5	Flow rate <sup>5)</sup>	6	Head <sup>9)</sup>
7	Rated speed	8	Efficiency
9	Mechanical seal (code, design)	10	Maximum pressure at specified temperature
11	Maximum temperature at specified pressure	12	Pressure class
13	Order number	14	Serial number
15	Week of production / year of production	16	Purchase order number
17	Manufacturer's address	18	Motor rating

## 4.4 Design details

### Design

- High-pressure in-line pump
- Maximum pressure class PN 25
- Centrifugal pump
- Single-stage or multistage

### Installation

- Horizontal installation

5) At best efficiency point (Qopt)

## Drive

- Surface-cooled DP squirrel-cage motor
- Thermal class F to IEC 34-1
- Efficiency class IE3 to IEC 60034-30 ( $\geq 0.75$  kW)
- Enclosure IP55
- Frequency 50 Hz/60 Hz

Optional:

- Harting connector, type HAN 10E

## Shaft seal

- Uncooled maintenance-free mechanical seal
  - Fixed mechanical seal
  - Easy Access mechanical seal
  - Cartridge mechanical seal

## Bearings

- Tungsten carbide plain bearings at the hydraulic rotor

## 4.5 Configuration and function

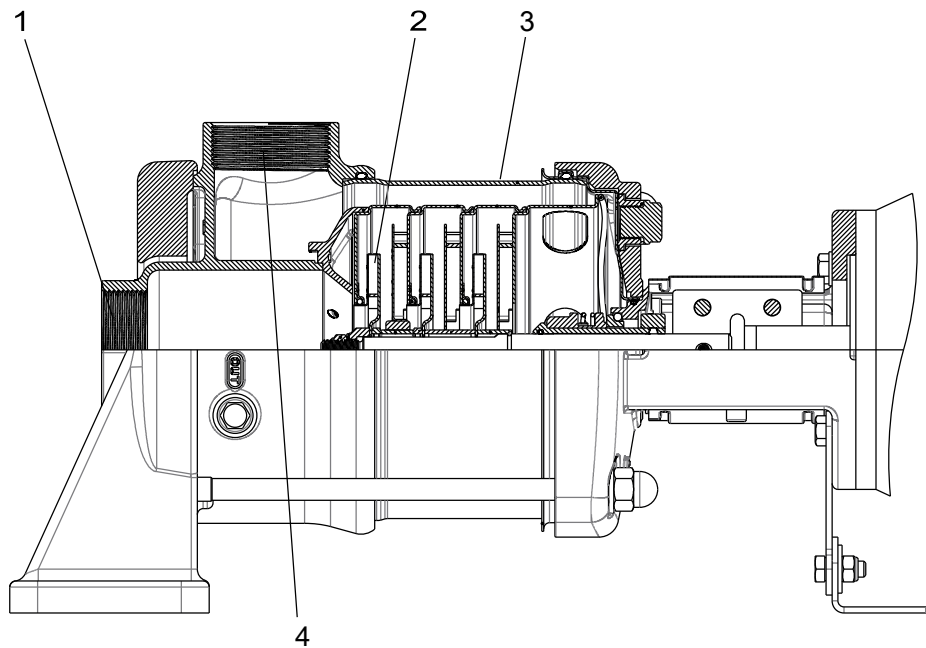

Fig. 3: Sectional drawing

1	Suction nozzle	3	Pump shroud
2	Impeller	4	Discharge nozzle

**Design** The pump is designed with a radial fluid inlet (suction nozzle) and a radial outlet (discharge nozzle) arranged on the same axis. The hydraulic system is rigidly connected to the motor by a shaft coupling.

**Function** During pump operation, a lower pressure forms at the impeller inlet. This lower pressure makes the fluid enter the pump via the suction nozzle (1). Each stage consists of one impeller (2) and one diffuser. The flow through a stage equals the flow rate of the pump. The



stage diameter is related to the centrifugal forces and the stage pressure. The more stages, the higher the pressure. The fluid is guided outwards to the area between the pump stages and the pump shroud (3), from where it leaves the pump via the discharge nozzle (4).

**Sealing** The pump is sealed by a standardised mechanical seal.

#### **4.6 Noise characteristics**

The noise characteristics given refer to the motor. See motor literature supplied.

#### **4.7 Scope of supply**

Depending on the model, the following items are included in the scope of supply:

- Pump
- Electric motor

#### **4.8 Dimensions and weights**

For dimensions and weights refer to the general arrangement drawing/outline drawing or data sheet of the pump set.

# 5 Installation at Site

## 5.1 Safety regulations

	<p><b>⚠ DANGER</b> <b>Installation in potentially explosive atmospheres</b> Explosion hazard!</p> <ul style="list-style-type: none"><li>➤ Never install the pump in potentially explosive atmospheres.</li><li>➤ Observe the information given in the data sheet and on the name plates of the pump system.</li></ul>
---	---

	<p><b>⚠ WARNING</b> <b>Pump with long-term preservation: Harmful preservatives in drinking water systems</b> Danger of poisoning!</p> <ul style="list-style-type: none"><li>➤ Flush the system prior to commissioning.</li><li>➤ If necessary, dismantle the pump and thoroughly remove the preservative from all wetted components.</li><li>➤ Observe the data given in the order confirmation.</li></ul>
---	--

## 5.2 Checks to be carried out prior to installation

### Place of installation

	<p><b>⚠ WARNING</b> <b>Installation on mounting surface which is unsecured and cannot support the load</b> Personal injury and damage to property!</p> <ul style="list-style-type: none"><li>➤ Use a concrete of compressive strength class C12/15 which meets the requirements of exposure class XC1 to EN 206-1.</li><li>➤ The mounting surface must be set, flat, and level.</li><li>➤ Observe the weights indicated.</li></ul>
---	--

1. Check the structural requirements.  
All structural work required must have been prepared in accordance with the dimensions stated in the outline drawing/general arrangement drawing.

## 5.3 Installing the pump set

	<p><b>CAUTION</b> <b>Ingress of leakage into the motor</b> Damage to the pump!</p> <ul style="list-style-type: none"><li>➤ Never install the pump set with the "motor below".</li></ul>
---	---

1. Install and fasten the pump set on a sturdy and level foundation in a dry and frost-proof room.
2. Make sure that sufficient air can reach the fan opening of the motor.  
(The clearance above the fan opening must measure at least  $\frac{1}{4}$  of the diameter of the fan cover air intake.)

3. Place a spirit level on the discharge nozzle to align the pump set.
4. Align the adjustable retaining bracket of the drive lantern with the floor by tightening the locknuts.
  - ⇒ The retaining bracket does not need to be fastened to the floor. This minimises stresses and strains in the pump.
5. Make sure that no clogging can occur in the suction nozzle of the pump.

## 5.4 Piping

### 5.4.1 Connecting the piping



#### **⚠ DANGER**

##### **Impermissible loads acting on the pump nozzles**

Danger to life from leakage of hot, toxic, corrosive or flammable fluids!

- Do not use the pump as an anchorage point for the piping.
- Anchor the pipes in close proximity to the pump and connect them properly without transmitting any stresses or strains.
- Take appropriate measures to compensate for thermal expansion of the piping.



#### **⚠ CAUTION**

##### **Incorrect earthing during welding work at the piping**

Destruction of rolling element bearings (pitting effect)!

- Never earth the electric welding equipment on the pump or baseplate.
- Prevent current flowing through the rolling element bearings.



#### **NOTE**

Installing check and shut-off elements in the system is recommended, depending on the type of plant and pump. However, such elements must not obstruct proper drainage or hinder disassembly of the pump.



#### **NOTE**

VdS-certified pumps must be connected in compliance with current information from VdS CEA 4001.

- ✓ Suction lift lines have been laid with a rising slope, suction head lines with a downward slope towards the pump.
  - ✓ A flow stabilisation section having a length equivalent to at least twice the diameter of the suction flange has been provided upstream of the suction flange.
  - ✓ The nominal diameters of the pipelines are equal to or greater than the nominal diameters of the pump nozzles.  
As far as the nominal diameters in the suction and discharge line, and installation of check valves and shut-off elements in a fire protection system are concerned, observe the sizing specifications in the relevant directives.
  - ✓ Adapters to larger nominal diameters are designed with a diffuser angle of approx. 8° to avoid excessive pressure losses.
  - ✓ The pipelines have been anchored in close proximity to the pump and connected without transmitting any stresses or strains.
1. Thoroughly clean, flush and blow through all vessels, pipelines and connections (especially of new installations).
  2. Before installing the pump in the piping, remove the flange covers on the suction and discharge nozzles of the pump.



### CAUTION

#### Welding beads, scale and other impurities in the piping

Damage to the pump!

- Remove any impurities from the piping.
- If necessary, install a filter.

3. If required, install a filter in the piping (see drawing: Filter in the piping).

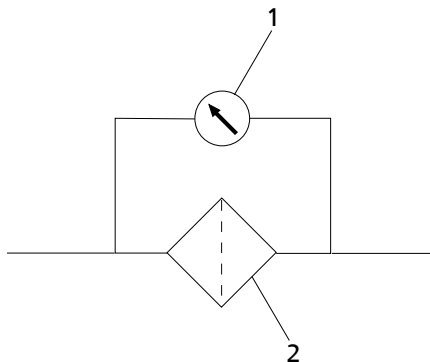

Fig. 4: Filter in the piping

1	Differential pressure gauge	2	Filter
---	-----------------------------	---	--------



### NOTE

Use a filter with laid-in wire mesh (mesh width 0.5 mm, wire diameter 0.25 mm) of corrosion-resistant material.  
Use a filter with a filter area three times the cross-section of the piping.  
Conical filters have proved suitable.

4. Connect the pump nozzles to the piping.



### CAUTION

#### Aggressive flushing liquid and pickling agent

Damage to the pump!

- Match the cleaning operation mode and duration of flushing and pickling to the casing materials and seal materials used.

## 5.4.2 Permissible forces and moments at the pump nozzles

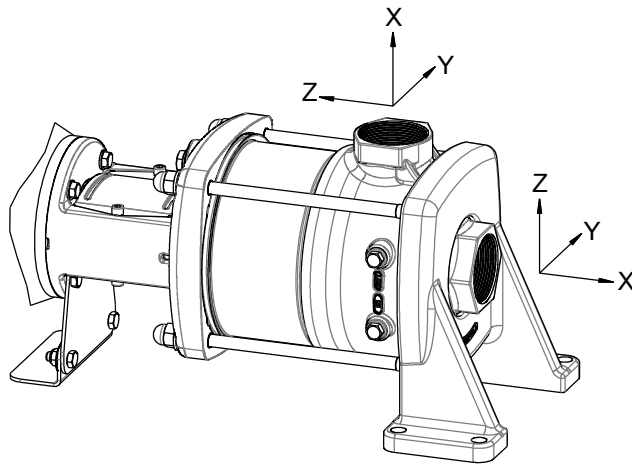

Fig. 5: Forces and moments at the pump nozzles

Table 6: Forces and moments at the pump nozzles

DPH(S)I	DN	$F_x$	$F_y$	$F_z$	$\Sigma F$	$M_x$	$M_y$	$M_z$	$\Sigma M$
	[mm]	[N]	[N]	[N]	[N]	[Nm]	[Nm]	[Nm]	[Nm]
2B	32	3300	1700	-2400	4420	280	210	95	360
4B	32	3300	1700	-2400	4420	280	210	95	360
6B	32	3300	1700	-2400	4420	280	210	95	360
10B	50	4000	3100	-3100	5930	440	200	180	520
15B	50	4000	3100	-3100	5930	440	200	180	520

## 5.5 Fitting a bypass



### NOTE

If the pump is operated against a closed valve, installing a bypass is recommended.  
The bypass capacity must correspond to at least 10 % of the optimum volume flow rate.

## 5.6 Electrical connection



### **⚠ DANGER**

#### **Incorrect connection**

Explosion hazard!

- The connection point of the cable ends must be located outside hazardous areas or in an area approved for electrical equipment.



### **⚠ DANGER**

#### **Operating a pump set that has not been fully connected**

Explosion hazard!

Damage to the pump set!

- Never start up a pump set with power cables that have not been fully connected or non-operational monitoring devices.



### **⚠ DANGER**

#### **Connection of damaged power cables**

Danger of death from electric shock!

- Check the power cables for damage before connecting them.
- Never connect damaged power cables.
- Replace damaged power cables.



### **⚠ DANGER**

#### **Electrical connection work by unqualified personnel**

Risk of fatal injury due to electric shock!

- Always have the electrical connections installed by a trained and qualified electrician.
- Observe regulations IEC 60364 and, for explosion-proof models, EN 60079.



### **⚠ WARNING**

#### **Incorrect connection to the mains**

Damage to the mains network, short circuit!

- Observe the technical specifications of the local energy supply companies.



### **CAUTION**

#### **Improper routing of power cable**

Damage to the power cables!

- Never move the power cables at temperatures below - 25 °C.
- Never kink or crush the power cables.
- Never lift the pump set by the power cables.
- Adjust the length of the power cables to the site requirements.



### **CAUTION**

#### **Pump (set) overload**

Damage to the machinery!

- Install a monitoring system that complies with the requirements of EN 13463-6.
- Protect the motor by a thermal time-lag overload protection device in accordance with IEC 947 and local regulations.  
(If the pump is used in a fire protection system as the main fire-fighting pump, the pump must not be tripped automatically by motor protection devices!)
- Make sure that the motor's specifications match those of the power supply it will be connected to.



### **NOTE**

Sprinkler pumps with VdS certification must not be able to be tripped automatically by measures of any kind.

For electrical connection observe the wiring diagrams in the Annex and the information for planning the control system.

If a motor of a different make is used, observe the relevant operating instructions.

The pump set is supplied with power cables as standard. Always use all cables provided and connect all marked cores of the control cable.

The permissible rated current of the motor supplied is shown on the motor name plate. It describes the permissible operating range of the motor and can be used for setting the overload protection device. If the actual power input is measured during operation, the motor protection switch can be pre-set to a lower value to protect the pump set. This current value can also be used to select appropriate electrical equipment such as frequency inverter, master switch, conductor diameter, etc.

## 5.7 Checking the direction of rotation



### **⚠ DANGER**

#### **Temperature increase resulting from contact between rotating and stationary components**

Damage to the pump set!

- Never check the direction of rotation by starting up the unfilled pump set.
- Separate the pump from the motor to check the direction of rotation.



### **⚠ WARNING**

#### **Hands inside the pump casing**

Risk of injuries, damage to the pump!

- Always disconnect the pump set from the power supply and secure it against unintentional start-up before inserting your hands or other objects into the pump.



### **CAUTION**

#### **Drive and pump running in the wrong direction of rotation**

Damage to the pump!

- Refer to the arrow indicating the direction of rotation on the pump.
- Check the direction of rotation. If required, check the electrical connection and correct the direction of rotation.

The correct direction of rotation of the motor and pump is clockwise (seen from the drive end).

1. Start the motor and stop it again immediately to determine the motor's direction of rotation.
2. Check the direction of rotation.  
The motor's direction of rotation must match the arrow indicating the direction of rotation on the pump.
3. If the motor is running in the wrong direction of rotation, check the electrical connection of the motor and the control system if applicable.

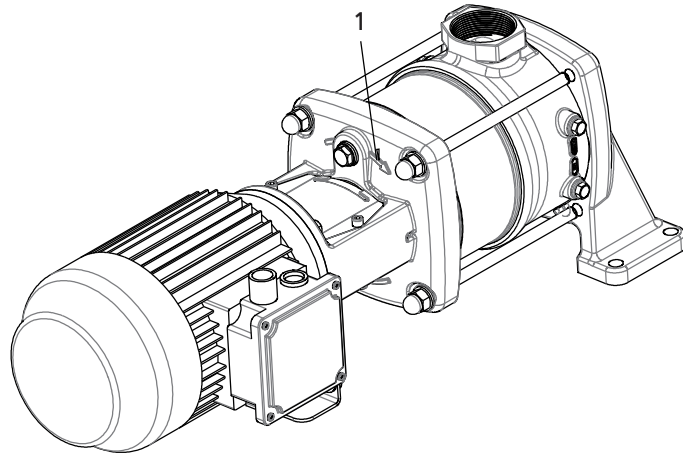

Fig. 6: Direction of rotation of the motor

1	Direction of rotation of the motor
---	------------------------------------



# 6 Commissioning/Start-up/Shutdown

## 6.1 Commissioning/Start-up

### 6.1.1 Prerequisites for commissioning/start-up

Before commissioning/starting up the pump set, make sure that the following conditions are met:

- The pump set has been installed correctly.
- The pump set has been properly connected to the power supply and is equipped with all protection devices.
- The pump has been primed with the fluid to be handled. The pump has been vented.
- The direction of rotation has been checked.
- All auxiliary connections required are connected and operational.
- Pump shaft and motor shaft are running smoothly and without any excessive noise.
- After prolonged shutdown of the pump (set), the activities required for returning the equipment to service have been carried out. [⇒ Section 6.4, Page 31]

The following must be ensured for a pump with a thrust bearing housing:

- The axial clearance between the thrust bearing housing and the motor shaft is set correctly.
- The thrust bearing housing is lubricated if the thrust bearing housing is equipped with a lubricating nipple.

### 6.1.2 Priming and venting the pump



#### **⚠ DANGER**

##### **Formation of a potentially explosive atmosphere inside the pump**

Explosion hazard!

- Before starting up the pump set, vent the pump and suction line and prime both with the fluid to be handled.



#### **CAUTION**

##### **Increased wear due to dry running**

Damage to the pump set!

- Never operate the pump set without liquid fill.
- Never close the shut-off element in the suction line and/or supply line during pump operation.

## Priming in an open or closed circuit with sufficient supply pressure

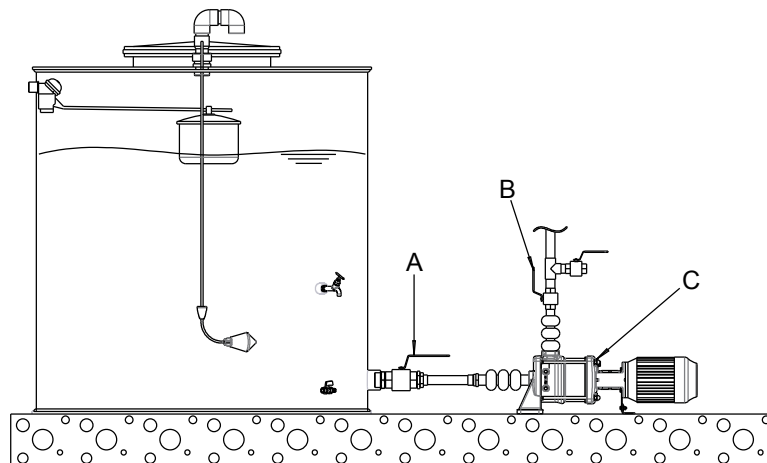

Fig. 7: Pump with open or closed circuit

A	Shut-off element in the suction line	B	Shut-off element in the discharge line
C	Filler opening		

1. Close the shut-off element in suction line A and the shut-off element in discharge line B.
2. Open filler opening C.
3. Open the shut-off element in suction line A gradually until fluid escapes from filler opening C.
4. Close filler opening C.
5. Open the shut-off element in suction line A.
6. Open the shut-off element in discharge line B.

### Priming in open circuit with fluid level below the pump

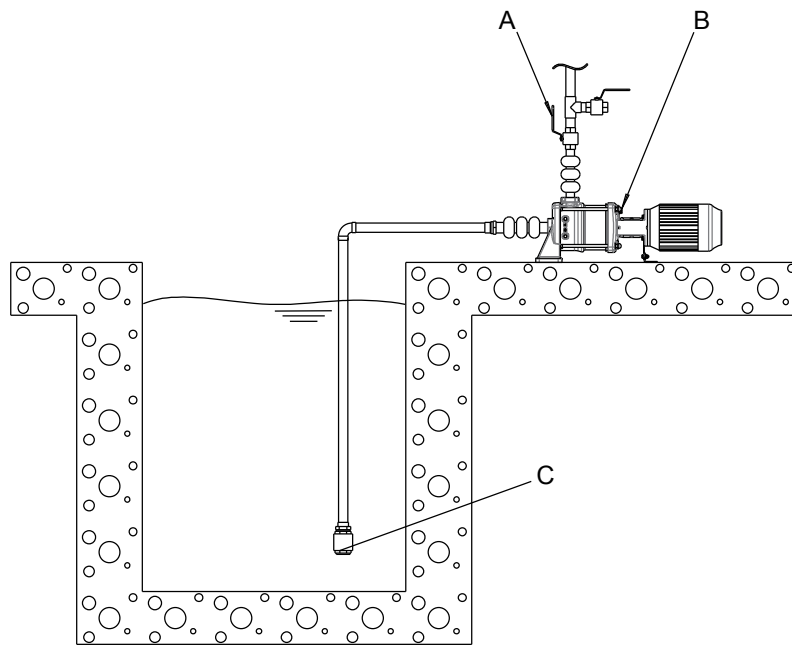

Fig. 8: Pump with open circuit and fluid level below the pump

A	Shut-off element in the discharge line	B	Filler opening
C	Foot valve		

1. Remove the plug of filler opening B from the upper support bracket.
2. Close the shut-off valve in discharge line A.
3. Fill fluid into the pump casing through filler opening B until the fluid reaches the maximum fill level.
4. Close filler opening B.
5. Open the shut-off element in discharge line A.

### Venting

The pump can be vented via the corresponding connections when it is not in operation.

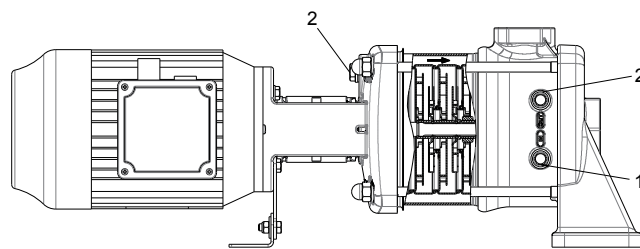

Fig. 9: Connections for draining the pump

1	Connection for draining the suction section	2	Connection for draining the discharge section
---	---	---	---

## 6.2 Operating limits



### **⚠ DANGER**

#### **Non-compliance with operating limits**

Damage to the pump set!

- Comply with the operating data indicated in the data sheet.
- Avoid operation against a closed shut-off element.
- Never operate the pump set outside the limits specified below.



### **⚠ DANGER**

#### **Non-compliance with operating limits for the fluid handled**

Explosion hazard!

- Never use the pump to handle different fluids which might react chemically with each other.
- Never use the pump to handle a flammable fluid with a fluid temperature above the ignition temperature.



### **CAUTION**

#### **Excessive temperature difference between the fluid handled and the pump**

Damage to the machinery!

- The temperature difference between the fluid handled and the pump must never exceed 60 °C.
- If the temperature difference between the pump and the fluid handled exceeds 30 °C, prime/heat up the pump slowly to avoid any risk of thermal shock.

The operating range depends on the application as well as on the combination of pressure and temperature.

Table 7: Specified operating range

Characteristic	Operating range
Ambient temperature [°C] <sup>6)</sup>	-20 to 40
Minimum inlet pressure	NPSH <sub>req</sub> + 1 m
Viscosity [cSt] <sup>7)</sup>	1 - 100
Density [kg/m <sup>3</sup> ] <sup>7)</sup>	1000 - 2500
Frequency [Hz] <sup>8)</sup>	30 - 60
Maximum number of starts per hour <sup>9)</sup>	See motor data sheet
Permissible particle size [mm]	0,005 - 1
Cooling <sup>10)</sup>	Forced cooling

- 6) If the ambient temperature exceeds the permissible maximum or if the motor is located more than 1000 metres above sea level, the motor cooling is less effective and the motor might have to be de-rated. The motor load depends on the installation altitude above sea level or on the ambient temperature. For detailed recommendations contact your sales house.
- 7) Fluctuations could require de-rating of the motor. For more detailed recommendations contact your sales house.
- 8) Pumps which are selected for 50 Hz must not be connected to a 60 Hz mains.
- 9) Excessive starting/stopping, particularly in combination with high pressure differences ( $\Delta p$ ) may reduce the service life of the product.
- 10) The clearance above the fan openings of the motor must measure at least 1/4 of the diameter of the fan openings to allow the (cooling) air to circulate properly.

## 6.2.1 Minimum flow rate and maximum flow rate

Table 8: Minimum flow rate and maximum flow rate Q at a fluid temperature  $\leq +20$  °C depending on the speed, 50 Hz

DPH(S)I	Q			
	2900 rpm		1450 rpm	
	Min.	Max.	Min.	Max.
	[m <sup>3</sup> /h]	[m <sup>3</sup> /h]	[m <sup>3</sup> /h]	[m <sup>3</sup> /h]
2B	0,2	3,3	-	-
4B	0,4	6,5	-	-
6B	0,6	9,0	-	-
10B	1,1	13,2	0,5	6,6
15B	1,6	22,5	0,8	11,3

Table 9: Minimum flow rate and maximum flow rate Q at a fluid temperature  $\leq +20$  °C depending on the speed, 60 Hz

DPH(S)I	Q			
	3500 rpm		1750 rpm	
	Min.	Max.	Min.	Max.
	[m <sup>3</sup> /h]	[m <sup>3</sup> /h]	[m <sup>3</sup> /h]	[m <sup>3</sup> /h]
2B	0,2	4,0	-	-
4B	0,5	7,8	-	-
6B	0,8	8,6	-	-
10B	1,3	15,8	0,6	7,9
15B	2,0	27,0	1,0	13,5

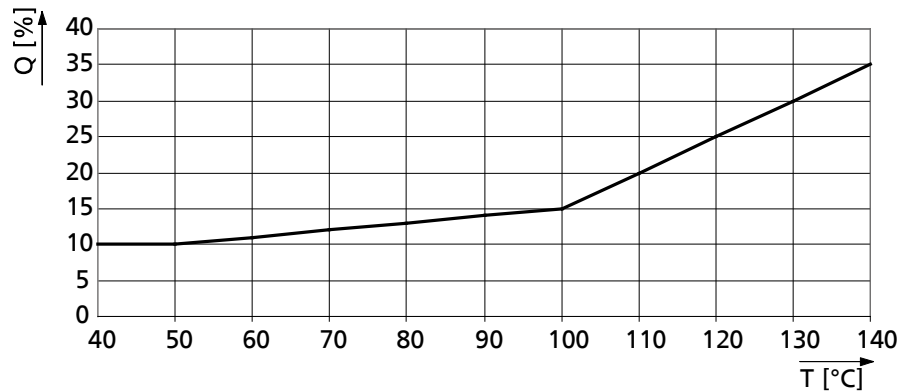

Fig. 10: Minimum flow rate required as a function of fluid temperature at a fluid temperature  $> +20$  °C

## 6.2.2 Pressure limits and temperature limits

### 6.2.2.1 Pressure limits and temperature limits

The pump's pressure limits and temperature limits are indicated on the name plate.

### 6.2.2.2 Shaft seal

Table 10: Available mechanical seals

Mechanical seal							T		p [bar]
Code	Type	Code to EN 12756	Elastomer	Design			Min.	Max.	
				C	E	F	[°C]	[°C]	
11	MG-G60	B Q1 E G G	EPDM	X	X	X	-20	+100	10
12	MG-G60	B Q1 V G G	FPM	X	X	X	-20	+120	10
13	RMG-G606	Q1 B E G G	EPDM WRAS / ACS	X	X	X	-20	+100	25
14	RMG-G606	Q1 B V G G	FPM	X	X	X	-20	+120	25
15	RMG-G606	U3 U3 X4 G G	HNBR	X	X	X	-20	+120 <sup>11)</sup>	25
16	RMG-G606	U3 U3 V G G	FPM	X	X	X	-20	+120 <sup>11)</sup>	25
18	RMG-G606	U3 B E G G	EPDM 559236	X	X	X	-20	+120 <sup>11)</sup>	25
23	RMG-G606	Q1 B E G G	EPDM	X	X	X	-20	+100	25
24	MG-G60	Q1 Q1 V G G	FPM	X	X	X	-20	+120	10
28	MG-G60	Q1 Q1 X4 G G	HNBR	X	X	X	-20	+120	10
29	MG-G60	Q1 Q1 E G G	EPDM	X	X	X	-20	+100	10

Table 11: Key to mechanical seal materials

Description	Code to EN 12756	Seal face materials / secondary seals
Primary ring	B	Hard carbon, resin-impregnated
	U3	Tungsten carbide (CrNiMo binder)
	Q1	Silicon carbide (sintered without pressure)
Mating ring	B	Hard carbon, resin-impregnated
	U3	Tungsten carbide (CrNiMo binder)
	Q1	Silicon carbide (sintered without pressure)
Elastomer	E	EPDM (ethylene propylene rubber)
	V	FPM (fluoroelastomer)
	X4	HNBR
Spring	G	CrNiMo steel
Other metal parts	G	CrNiMo steel

### 6.2.3 Rated current and maximum current

The permissible rated current of the motor supplied is shown on the motor name plate. It describes the permissible operating range of the motor and can be used for setting the overload protection device. If the actual power input is measured during operation, the motor protection switch can be pre-set to a lower value to protect the pump set. This current value can also be used to select appropriate electrical equipment such as frequency inverter, master switch, conductor diameter, etc.

## 6.3 Shutdown/storage/preservation

### 6.3.1 Measures to be taken for shutdown

#### The pump set remains installed

- ✓ Sufficient fluid is supplied for the operation check run of the pump.
- 1. Start up the pump regularly once a month or once every three months for approximately five minutes during prolonged shutdown periods.  
This will prevent the formation of deposits within the pump and the pump intake area.

11) Temperatures up to 140 °C if the pressure does not exceed 16 bar



### CAUTION

#### Danger of freezing during prolonged pump shutdown periods

Damage to the pump!

- The temperature maintenance equipment must remain in operation also during pump shutdown periods.

#### The pump set is removed from the piping and stored

- ✓ The checks and maintenance operations have been performed.
- 1. Spray-coat the inside wall of the pump casing with a preservative.
- 2. Spray the preservative through the inlet and outlet nozzles of the fluid handled.  
It is advisable to close the fluid inlet and outlet nozzles afterwards (e.g. with plastic caps or similar).

Observe any additional instructions and information provided. [⇒ Section 3, Page 11]

## 6.4 Returning to service

For returning the equipment to service, observe the sections on commissioning/start-up [⇒ Section 6.1, Page 25] and the operating limits.

In addition, carry out all servicing/maintenance operations before returning the pump (set) to service. [⇒ Section 7, Page 32]



### WARNING

#### Failure to re-install or re-activate protective devices

Risk of injury from moving parts or escaping fluid!

- As soon as the work is completed, re-install and re-activate any safety-relevant devices and protective devices.



### NOTE

If the pump has been out of service for more than one year, replace all elastomer seals.

# 7 Servicing/Maintenance

## 7.1 Safety regulations



### **⚠ DANGER**

#### **Sparks produced during servicing work**

Explosion hazard!

- Observe the safety regulations in force at the place of installation!
- Never open an energised pump set.
- Always perform maintenance work on pump sets outside potentially explosive atmospheres only.



### **⚠ DANGER**

#### **Improperly serviced pump set**

Explosion hazard!

Damage to the pump set!

- Service the pump set regularly.
- Prepare a maintenance schedule with special emphasis on lubricants, shaft seal and coupling.

The operator ensures that maintenance, inspection and installation is performed by authorised, qualified specialist personnel who are thoroughly familiar with the manual.



### **⚠ WARNING**

#### **Unintentional starting of the pump set**

Risk of injury by moving components and shock currents!

- Ensure that the pump set cannot be started unintentionally.
- Always make sure the electrical connections are disconnected before carrying out work on the pump set.



### **⚠ WARNING**

#### **Fluids handled, consumables and supplies which are hot and/or pose a health hazard**

Risk of injury!

- Observe all relevant laws.
- When draining the fluid take appropriate measures to protect persons and the environment.
- Decontaminate pumps which handle fluids posing a health hazard.



### **⚠ WARNING**

#### **Insufficient stability**

Risk of crushing hands and feet!

- During assembly/dismantling, secure the pump (set)/pump parts to prevent tilting or tipping over.

A regular maintenance schedule will help avoid expensive repairs and contribute to trouble-free, reliable operation of the pump, pump set and pump parts with a minimum of servicing/maintenance expenditure and work.





## NOTE

All maintenance work, service work and installation work can be carried out by DP Service or authorised workshops.

Never use force when dismantling and reassembling the pump set.

## 7.2 Servicing/inspection

### 7.2.1 Supervision of operation



#### **⚠ DANGER**

##### **Formation of a potentially explosive atmosphere inside the pump**

Explosion hazard!

- Before starting up the pump set, vent the pump and suction line and prime both with the fluid to be handled.



#### **⚠ DANGER**

##### **Incorrectly serviced shaft seal**

Fire hazard!

Hot fluids escaping!

Damage to the pump set!

- Regularly service the shaft seal.



#### **⚠ DANGER**

##### **Excessive temperatures as a result of bearings running hot or defective bearing seals**

Fire hazard!

Damage to the pump set!

- Regularly check the condition of the lubricant.
- Regularly check the rolling element bearings for running noises.



#### **CAUTION**

##### **Increased wear due to dry running**

Damage to the pump set!

- Never operate the pump set without liquid fill.
- Never close the shut-off element in the suction line and/or supply line during pump operation.



#### **CAUTION**

##### **Impermissibly high temperature of fluid handled**

Damage to the pump!

- Prolonged operation against a closed shut-off element is not permitted (heating up of the fluid).
- Observe the temperature limits in the data sheet and in the section on operating limits.

While the pump is in operation, observe and check the following:

- The pump must run quietly and free from vibrations at all times.
- Check the shaft seal.  
Visual inspection while rotating the shaft once by hand.
- Check the static seals for leakage.  
No leakage from the seals is allowed.
- Check the rolling element bearings for running noises.  
Vibrations, noise and an increase in current input occurring during unchanged operating conditions indicate wear.
- Monitor the correct functioning of any auxiliary connections.

## 7.2.2 Lubrication and lubricant change



	<p><b>⚠ DANGER</b> <b>Excessive temperatures as a result of bearings running hot or defective bearing seals</b> Fire hazard! Damage to the pump set!</p> <ul style="list-style-type: none"><li>➤ Regularly check the condition of the lubricant.</li><li>➤ Regularly check the rolling element bearings for running noises.</li></ul>
---	---

### 7.2.2.1 Grease lubrication

The bearings are supplied packed with high-quality lithium-soap grease.

#### 7.2.2.1.1 Intervals

Depending on the pump size and rotational speed, re-lubricate the rolling element bearings at regular intervals or replace the grease in the rolling element bearings.

	<p><b>NOTE</b> On some pump designs the rolling element bearings are lubricated for life. These pumps are not provided with a lubricating nipple on the bearing bracket.</p>
	<p><b>NOTE</b> If re-lubrication intervals are short, we recommend that the grease be completely replaced once a year. Otherwise, the grease fill must be replaced completely every two years. To do so, remove the rolling element bearings, clean and pack with new grease.</p>

Motors with lubricating nipple must be re-lubricated every 2000 hours.

If the pump is operated under extreme conditions, such as vibrations or high temperatures, the motors must be re-lubricated more frequently.

#### 7.2.2.1.2 Grease quality

##### Optimum grease properties for rolling element bearings

- High melting point lithium soap base grease
- Resin-free and acid-free
- Not liable to crumble
- Rust-preventive characteristics

### 7.2.2.1.3 Grease quantity

Use 15 grams of grease per bearing.

### 7.2.2.1.4 Re-lubricating with grease



#### **WARNING**

**Work in the immediate vicinity of rotating parts**

Risk of hand injuries!

- Always have this work performed by trained personnel.
- Take particular caution when performing this work.



#### **CAUTION**

**Contaminated lubricating nipples**

Contamination of the lubricating grease!

- Clean the grease lubricating nipples before re-lubricating them.

1. Clean the lubricating nipples, if contaminated.
2. Position the grease press on the lubricating nipple.
3. Press in the grease.

## 7.3 Drainage/cleaning



#### **WARNING**

**Fluids handled, consumables and supplies which are hot and/or pose a health hazard**

Hazard to persons and the environment!

- Collect and properly dispose of flushing fluid and any fluid residues.
- Wear safety clothing and a protective mask if required.
- Observe all legal regulations on the disposal of fluids posing a health hazard.

If the pump set has handled liquids whose residues could lead to corrosion damage in the presence of atmospheric humidity or could ignite upon contact with oxygen, the pump (set) must be flushed, neutralised, and anhydrous inert gas must be blown through the pump to ensure drying.

The pump is fitted with nozzles for draining.  
The pump must not be drained while it is in operation!

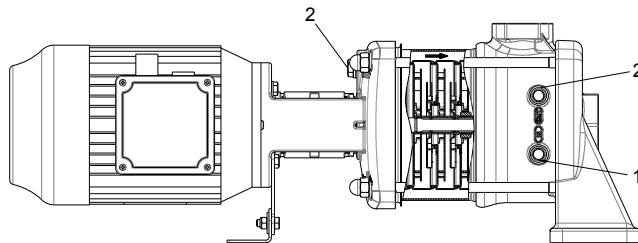

Fig. 11: Connections for draining the pump

1	Connection for draining the suction section	2	Connection for draining the discharge section
---	---	---	---

## 7.4 Dismantling the pump set

### 7.4.1 General information/Safety regulations



#### **⚠ DANGER**

##### **Insufficient preparation of work on the pump (set)**

Risk of injury!

- Properly shut down the pump set.
- Close the shut-off elements in the suction line and discharge line.
- Drain the pump and release the pump pressure.
- Shut off any auxiliary feed lines.
- Allow the pump set to cool down to ambient temperature.



#### **⚠ WARNING**

##### **Unqualified personnel performing work on the pump (set)**

Risk of injury!

- Always have repair work and maintenance work performed by specially trained, qualified personnel.



#### **⚠ WARNING**

##### **Hot surface**

Risk of injury!

- Allow the pump set to cool down to ambient temperature.



#### **⚠ WARNING**

##### **Improper lifting/moving of heavy assemblies or components**

Personal injury and damage to property!

- Use suitable transport devices, lifting equipment and lifting tackle to move heavy assemblies or components.

Always observe the safety instructions and information.

For any work on the motor, observe the instructions of the relevant motor manufacturer.

For dismantling and reassembly observe the exploded views and the general assembly drawing.

In the event of damage you can always contact our service staff.



#### **NOTE**

All maintenance work, service work and installation work can be carried out by DP Service or authorised workshops.



#### **NOTE**

After a prolonged period of operation the individual components may be hard to pull off the shaft. If this is the case, use a brand name penetrating agent and/or - if possible - an appropriate puller.

## 7.4.2 Preparing the pump set



### **⚠ DANGER**

**Power supply not disconnected**

Danger to life!

- Disconnect all electrical connections from the power supply and secure against unintentional start-up.

1. De-energise the pump set and secure it against unintentional start-up.

## 7.4.3 Removing the motor



### **⚠ WARNING**

**Motor tilting**

Risk of crushing hands and feet!

- Suspend or support the motor to prevent it from tilting.

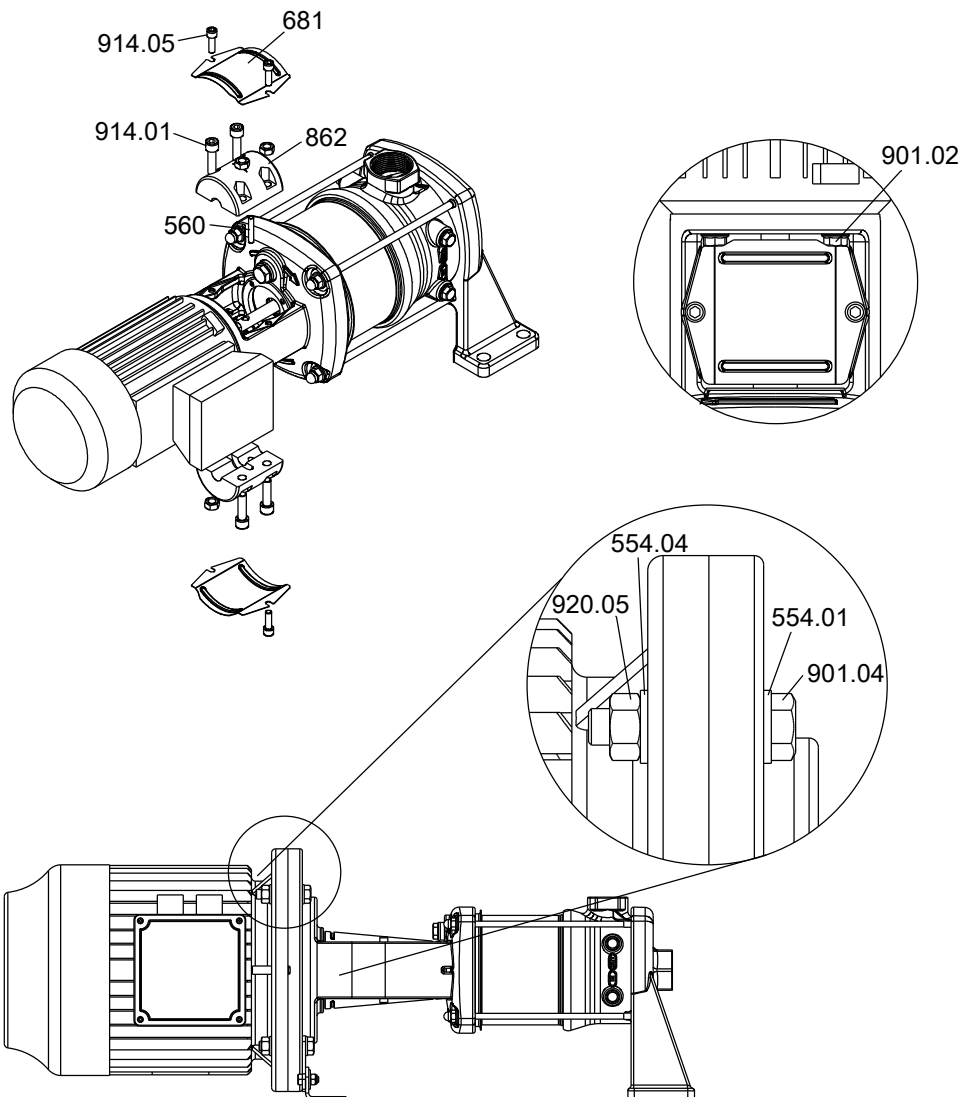

Fig. 12: Removing the motor (example drawing)

- ✓ The pump set has been de-energised.
- 1. Undo hexagon socket head cap screws 914.05.
- 2. Remove coupling guard 681.
- 3. Undo hexagon socket head cap screws 914.01.
- 4. Take off coupling 862 with pin 560.
- 5. Unscrew and remove hexagon head bolts 901.02 or 901.04 with nut 920.05 and washers 554.01 and 554.04.
- 6. Lift the motor off the pump.

#### 7.4.4 Removing the retaining bracket (optional)

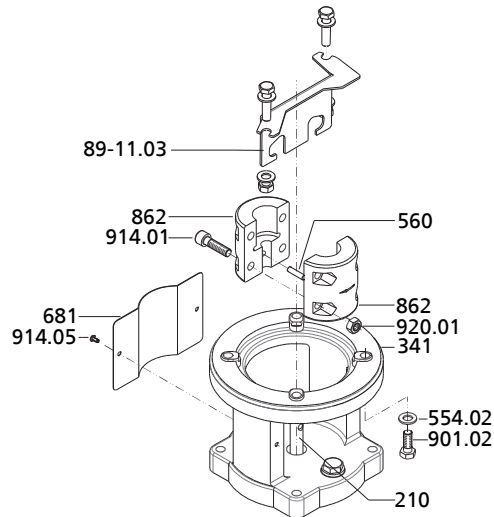

Fig. 13: Removing retaining bracket 89-11.03

- ✓ The motor has been removed.
- 1. Remove retaining bracket 89-11.03

#### 7.4.5 Removing the mechanical seal

##### 7.4.5.1 Fixed mechanical seal

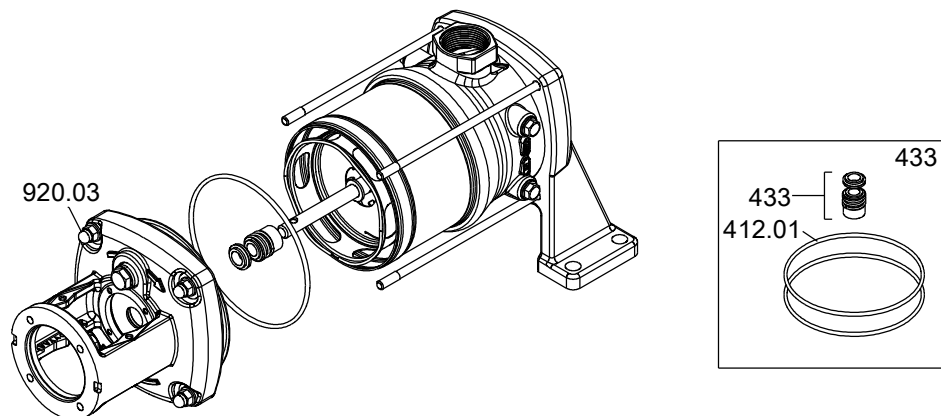

Fig. 14: Removing the mechanical seal (example drawing)

- ✓ The motor has been removed.
- 1. Loosen nuts 920.03 and lift off the drive lantern.
- 2. Remove mechanical seal 433 and O-rings 412.01.

#### 7.4.5.2 Easy Access mechanical seal

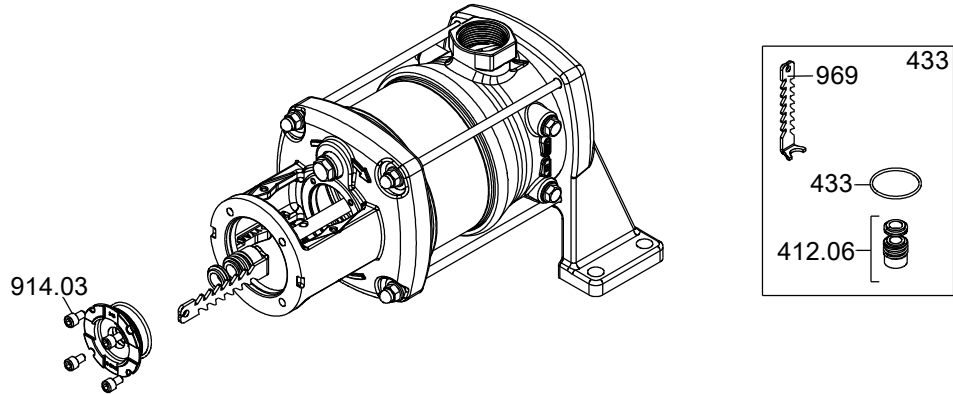

Fig. 15: Removing the mechanical seal (example drawing)

- ✓ The motor has been removed.
- 1. Loosen hexagon socket head cap screws 914.03.
- 2. Remove O-ring 412.06.
- 3. Remove mechanical seal 433 using tool 969.

#### 7.4.5.3 Cartridge mechanical seal

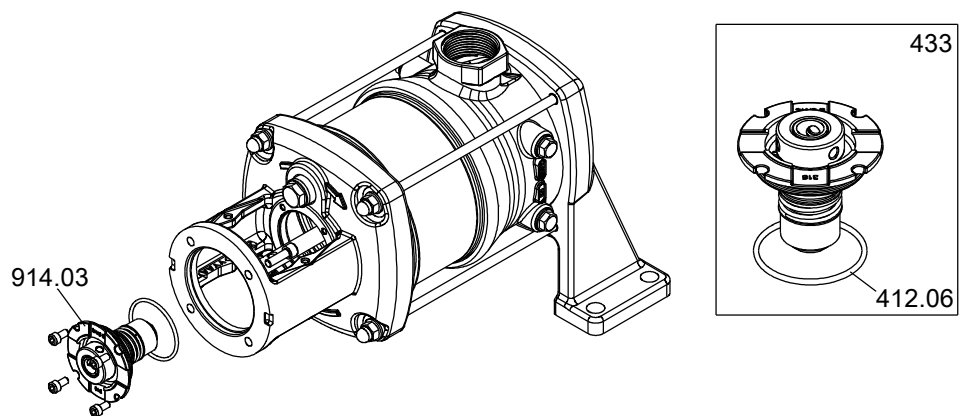





Fig. 16: 19486438667

- ✓ The motor has been removed.
- 1. Loosen hexagon socket head cap screws 914.03.
- 2. Remove mechanical seal 433.
- 3. Remove O-ring 412.06.

## 7.5 Reassembling the pump set

### 7.5.1 General information/Safety regulations

	<b>WARNING</b> <b>Improper lifting/moving of heavy assemblies or components</b> Personal injury and damage to property! ➤ Use suitable transport devices, lifting equipment and lifting tackle to move heavy assemblies or components.
	<b>CAUTION</b> <b>Improper reassembly</b> Damage to the pump! ➤ Reassemble the pump (set) in accordance with the general rules of sound engineering practice. ➤ Use original spare parts only.
	<b>NOTE</b> Use suitable tools for setting the pump shaft. If necessary, contact DP.

**Sequence** Always reassemble the pump set in accordance with the corresponding general assembly drawing.

- Sealing elements**
- O-rings
    - Check O-rings for any damage and replace by new O-rings, if required.
  - Assembly adhesives
    - Avoid the use of assembly adhesives, if possible.

**Tightening torques** For reassembly, tighten all screws and bolts as specified in this manual.

### 7.5.2 Installing the mechanical seal

	<b>CAUTION</b> <b>Incorrect installation of mechanical seal</b> Damage to the machinery! ➤ Assembly/installation should only be carried out by qualified specialist personnel.
---	---

**Installing the mechanical seal** The following rules must be observed when installing the mechanical seal:

- Work cleanly and accurately.
- Only remove the protective wrapping of the contact faces immediately before installation takes place.
- Prevent any damage to the sealing surfaces or O-rings.



### 7.5.2.1 Fixed mechanical seal

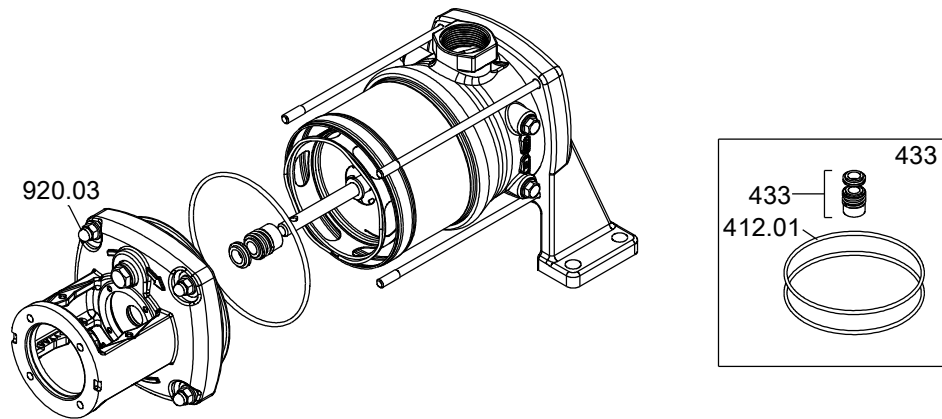

Fig. 17: Installing the mechanical seal (example drawing)

1. Insert mechanical seal 433 and O-rings 412.01.
2. Fit the drive lantern. Screw on nuts 920.03 and tighten them crosswise.
3. Adjust mechanical seal 433.

### 7.5.2.2 Easy Access mechanical seal

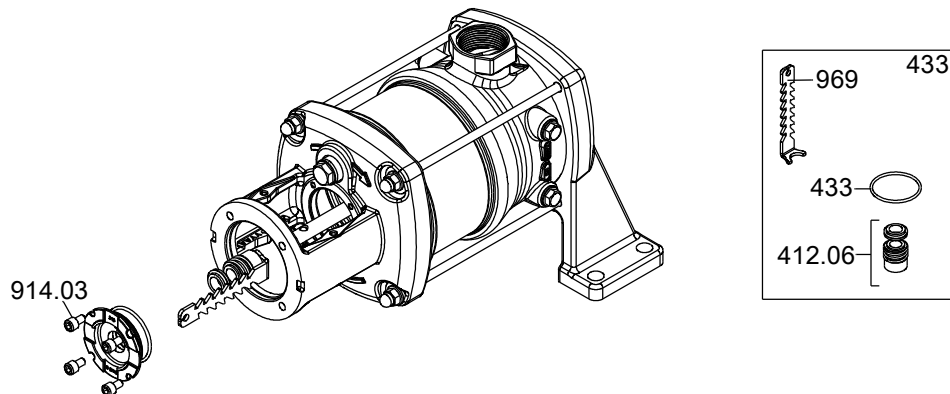

Fig. 18: Installing the mechanical seal (example drawing)

1. Insert mechanical seal 433 using tool 969.
2. Insert O-ring 412.06.
3. Screw in hexagon socket head cap screws 914.03.
4. Adjust mechanical seal 433.

### 7.5.2.3 Cartridge mechanical seal

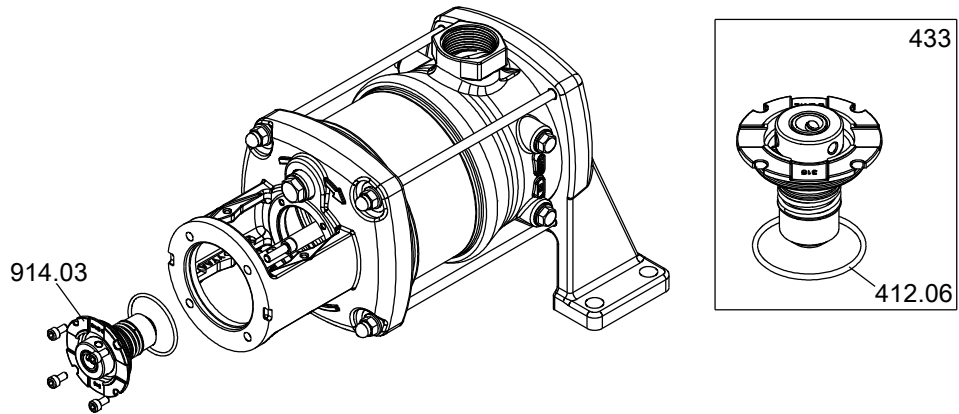

Fig. 19: Installing the mechanical seal (example drawing)

1. Insert O-ring 412.06.
2. Insert mechanical seal 433.
3. Screw in hexagon socket head cap screws 914.03.
4. Adjust mechanical seal 433.

### 7.5.3 Mounting the motor



#### **WARNING**

##### **Motor tilting**

Risk of crushing hands and feet!

- Suspend or support the motor to prevent it from tilting.



#### **NOTE**

Using a specially designed DP motor is recommended.

The motor must meet the following conditions:

- Reinforced bearing at the driven end (absorbing the axial forces)
- Motor fastened axially (minimising the axial clearance of the hydraulic system of the pump)
- Non-keywayed shaft (improving the coupling connection and smooth running of the motor)
- The rated power must be suitable for the relevant operating frequency.
- The frame size must be suitable for connecting the motor to the drive lantern.

Table 12: Recommended motor bearing at the drive end

Motor rating [kW]	1-phase 50 Hz	3-phase 50/60 Hz	
		2 poles	4 poles
0,25	-	-	6202-2Z-C3
0,37	6202-2Z-C3	6203-2Z-C3	6202-2Z-C3
0,55	6202-2Z-C3	6203-2Z-C3	6202-2Z-C3
0,75	6204-2Z-C3	6204-2Z-C3	6202-2Z-C3
1,1	6204-2Z-C3	6204-2Z-C3	6205-2Z-C3
1,5	6305-2Z-C3	6305-2Z-C3	6205-2Z-C3
2,2	6305-2Z-C3	6305-2Z-C3	6206-2Z-C3

Motor rating	1-phase 50 Hz	3-phase 50/60 Hz	
[kW]		2 poles	4 poles
3,0	-	6306-2Z-C3	6206-2Z-C3
4,0	-	6306-2Z-C3	6208-2Z-C3
5,5	-	6308-2Z-C3	6208-2Z-C3
7,5	-	6308-2Z-C3	6208-2Z-C3

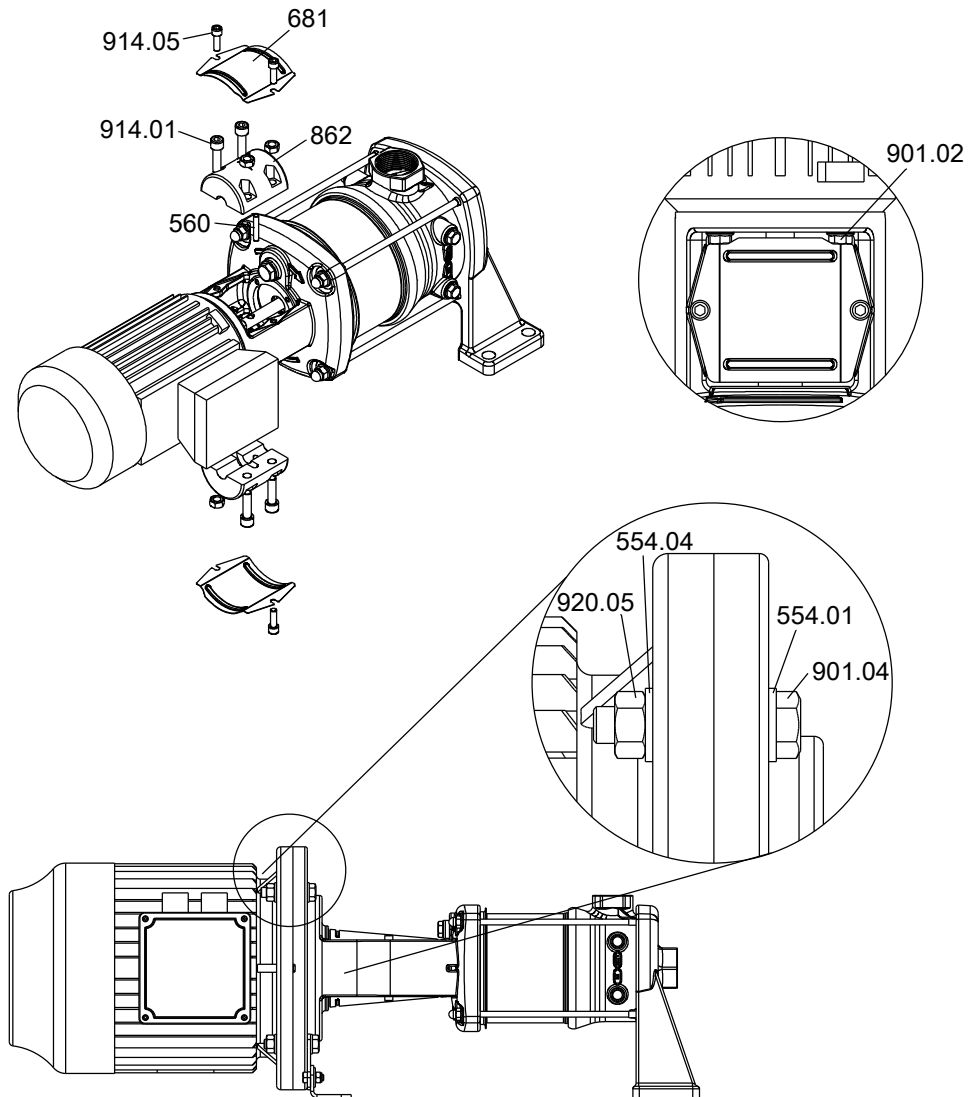

Fig. 20: Mounting the motor (example drawing)

✓ Retaining bracket 89-11.03 (if applicable) has been removed.  
[⇒ Section 7.4.4, Page 38]

1. Align the motor on the drive lantern.
2. Screw in hexagon head bolts 901.02 / 901.04 and washers 554.01 / 554.04.



### CAUTION

#### Incorrect installation of coupling

Damage to the machinery!

- The coupling must be installed by qualified specialist personnel.

3. Insert coupling 862 with pin 560.

4. Screw in hexagon socket head cap screws 914.01.
5. Fit coupling guard 681.
6. Screw in hexagon socket head cap screws 914.05.

### 7.5.4 Adjusting the mechanical seal, coupling and pump shaft



#### NOTE

Use suitable tools for setting the pump shaft.  
If necessary, contact DP.

#### Fixed mechanical seal / Easy Access mechanical seal

- ✓ The motor has been mounted on the pump.
  - ✓ Coupling 862 has been fastened with pin 560 and hexagon socket head cap screws 914.01.
1. Loosen hexagon socket head cap screws 914.01 by one turn each.
  2. Lower the coupling 862 to its lowest position, then raise it again by 1.5 mm.

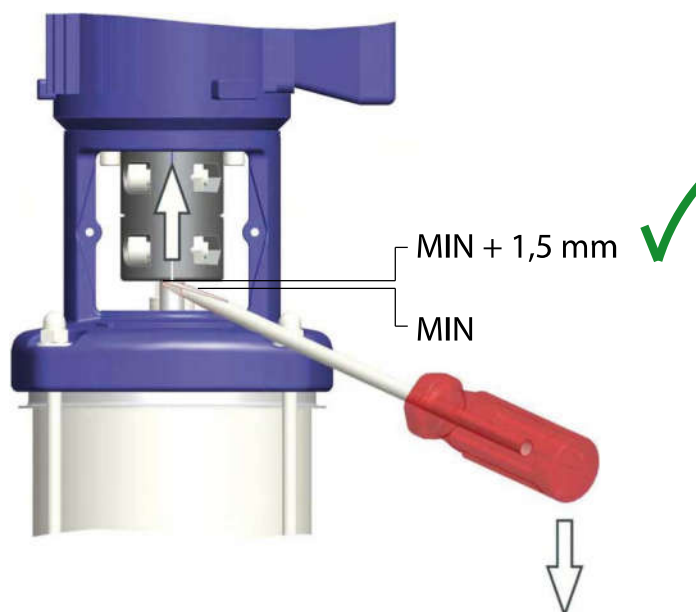

3. Verify that no clearances remain between the coupling halves, and fasten the coupling in this position.

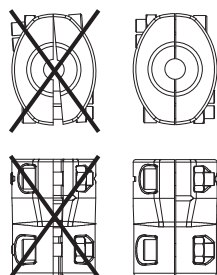

4. Apply a thread-locking agent (e.g. Loctite 2400).
5. Fit coupling guard 681 and fasten it with hexagon socket head cap screws 914.05. Tighten the screws.

### Cartridge mechanical seal

- ✓ The motor has been mounted on the pump.
  - ✓ Coupling 862 has been fastened with pin 560 and hexagon socket head cap screws 914.01.
1. Adjust grub screws 904.
  2. Loosen hexagon socket head cap screws 914.01 by one turn each.
  3. Apply a thread-locking agent (e.g. Loctite 2400).
  4. Move coupling 862 into its lowest position.
  5. Tighten grub screws 904.
  6. Raise coupling 862 by 1.5 mm.

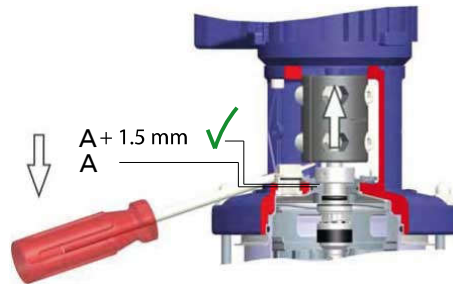

7. Tighten hexagon socket head cap screws 914.04.
8. Verify that no clearances remain between the coupling halves, and fasten the coupling in this position.

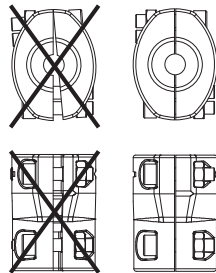

9. Apply a thread-locking agent (e.g. Loctite 2400).
10. Fit coupling guard 681 and fasten it with hexagon socket head cap screws 914.05. Tighten the screws.

## 7.6 Tightening torques

Table 13: Tightening torques

Part No.	Description	Thread	Tightening torques
			[Nm]
801	Flanged motor	M6	10
		M12	70
903.01	Screw plug	G 3/8	15
903.02	Screw plug	G 1/4	15 <sup>12)</sup>
914.01	Hexagon socket head cap screw	M6 steel	16
		M8 steel / grey cast iron	30
		M8 aluminium	22
		M10	70
914.02	Hexagon socket head cap screw	M6	10
		M8	10
		M10	50
914.03	Hexagon socket head cap screw	M5	4 <sup>+2</sup>
920.02	Nut	M10	28
920.03	Nut	M8	12
		M12	25

## 7.7 Spare parts stock

### 7.7.1 Ordering spare parts

Always quote the following data when ordering replacement or spare parts:

- Order number
- Order item number
- Consecutive number
- Type series
- Size
- Material variant
- Seal code
- Year of construction

Refer to the name plate for all data.

Also specify the following data:

- Part number and description [⇒ Section 9.1, Page 49]
- Quantity of spare parts
- Shipping address
- Mode of dispatch (freight, mail, express freight, air freight)

12) For Movitec 45, 65 and LHS 6 = 10 Nm

# 8 Trouble-shooting



**⚠ WARNING**  
**Improper work to remedy faults**  
 Risk of injury!

➤ For any work performed to remedy faults, observe the relevant information given in this operating manual and/or in the product literature provided by the accessories manufacturer.

If problems occur that are not described in the following table, consultation with the DP customer service is required.

Table 14: Trouble-shooting

Problem	Possible cause	Remedy
Leakage along the shaft	Seal faces of the primary rings of the mechanical seal worn or damaged	<ul style="list-style-type: none"> <li>- Replace the shaft seal.</li> <li>- Check pump for impurities.</li> </ul>
	Axial movement of the mechanical seal is restricted because it is stuck.	<ul style="list-style-type: none"> <li>- Quickly open and close the discharge-side valve during operation.</li> </ul>
	Shaft seal fitted incorrectly	<ul style="list-style-type: none"> <li>- Re-install shaft seal correctly (use water and soap as a lubricant).</li> </ul>
	Elastomers damaged by the fluid handled	<ul style="list-style-type: none"> <li>- Use a suitable elastomer for the shaft seal.</li> </ul>
	Total operating pressure too high	<ul style="list-style-type: none"> <li>- Use a shaft seal with suitable pressure class.</li> </ul>
	Shaft is damaged.	<ul style="list-style-type: none"> <li>- Replace the shaft.</li> </ul>
	Pump running dry	<ul style="list-style-type: none"> <li>- Replace the shaft seal.</li> </ul>
Leakage at the casing cover and the lower section of the pump casing	O-ring worn	<ul style="list-style-type: none"> <li>- Replace the O-ring.</li> </ul>
	O-ring not resistant to fluid handled	<ul style="list-style-type: none"> <li>- Replace O-ring with O-ring made of suitable material.</li> </ul>
	Pump not installed free from stresses and strains	<ul style="list-style-type: none"> <li>- Connect the piping properly.</li> </ul>
Pump vibrates and causes running noises.	Coupling fitted incorrectly	<ul style="list-style-type: none"> <li>- Make sure the coupling halves are parallel.</li> </ul>
	Rotor adjusted incorrectly	<ul style="list-style-type: none"> <li>- Re-adjust rotor.</li> </ul>
	Pump not primed.	<ul style="list-style-type: none"> <li>- Prime and vent the pump.</li> </ul>
	No or insufficient inflow	<ul style="list-style-type: none"> <li>- Provide sufficient supply.</li> <li>- Check inlet line for clogging.</li> </ul>
	Bearings of pump and/or motor defective	<ul style="list-style-type: none"> <li>- Replace bearings.</li> </ul>
	NPSH available too low (cavitation)	<ul style="list-style-type: none"> <li>- Improve suction conditions.</li> </ul>
	Pump not working in its operating range	<ul style="list-style-type: none"> <li>- Adjust system to operation within operating range or select different pump.</li> </ul>
	Pump clogged	<ul style="list-style-type: none"> <li>- Clean the pump.</li> </ul>
	Pump positioned on an uneven surface	<ul style="list-style-type: none"> <li>- Level the surface or rigidly fasten pump to installation surface.</li> </ul>
Pump does not start.	No voltage at the terminals	<ul style="list-style-type: none"> <li>- Check power supply (circuit, master switch, fuses).</li> </ul>
	Thermal motor protection device has tripped.	<ul style="list-style-type: none"> <li>- Re-set thermal motor protection (<math>I_{nom}</math> see name plate).</li> </ul>
Motor running but pump does not start.	Motor shaft defective	<ul style="list-style-type: none"> <li>- Contact supplier.</li> </ul>
	Pump shaft defective	<ul style="list-style-type: none"> <li>- Contact supplier.</li> </ul>
	Shaft coupling has become loose.	<ul style="list-style-type: none"> <li>- Tighten the fastening screws.</li> </ul>
Insufficient delivery and/or insufficient pressure	Valves in suction and discharge lines closed	<ul style="list-style-type: none"> <li>- Open the shut-off elements.</li> </ul>
	Air in the pump	<ul style="list-style-type: none"> <li>- Vent the pump.</li> </ul>



<b>Problem</b>	<b>Possible cause</b>	<b>Remedy</b>
Insufficient delivery and/or insufficient pressure	Insufficient inlet pressure	– Increase inlet pressure.
	Wrong direction of rotation	– Check electrical connection.
	Suction line not vented.	– Vent suction line.
	Air pocket in suction line	– Lay suction line with a rising slope towards the pump.
	Pump takes in air due to leakage in suction line.	– Repair.
	Insufficient flow rate leads to air remaining in the pump.	– Use smaller pump. – Increase the (volume) flow rate.
	Diameter of suction line too small	– Increase diameter of suction line.
	Foot valve clogged.	– Clean the foot valve.
	Impeller or diffuser clogged	– Clean the pump.
	O-ring not resistant to fluid handled	– Replace O-ring with O-ring made of suitable material.



# 9 Related Documents

## 9.1 General assembly drawings/exploded views with list of components

### 9.1.1 DPH(S)I

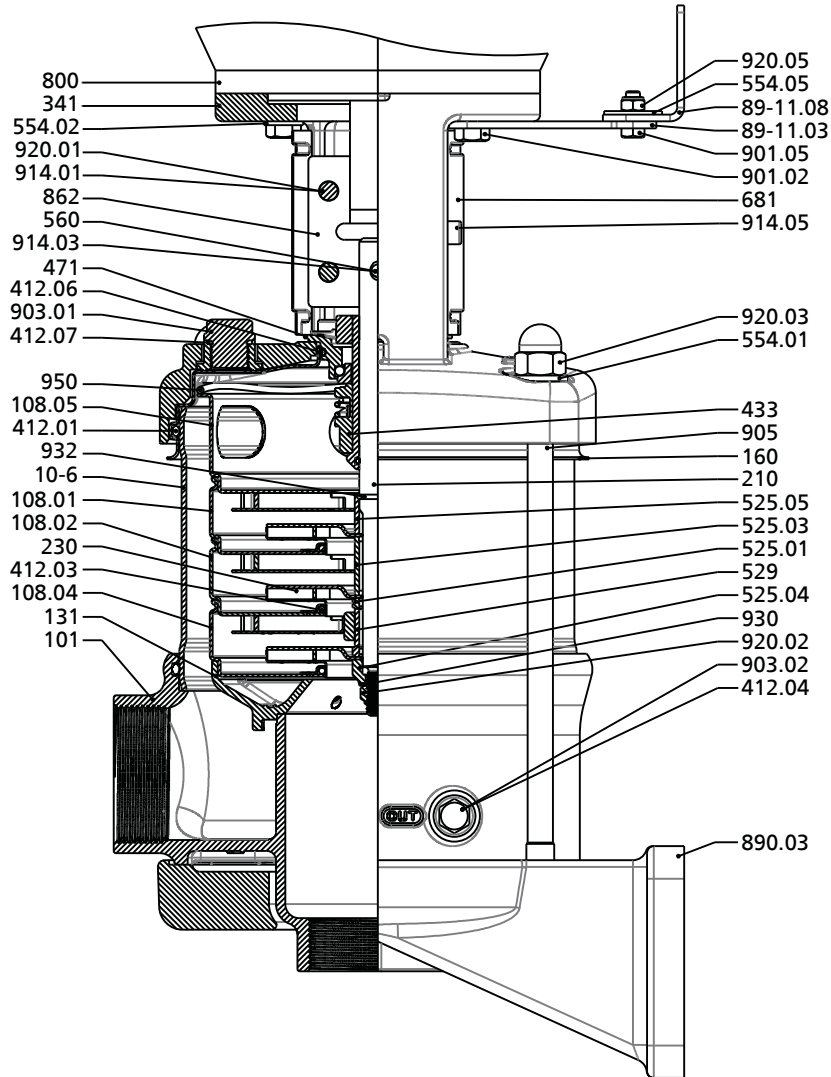

Fig. 21: General assembly drawing

Table 15: List of components

Part No.	Description	Part No.	Description
10-6	Pump shroud	560	Pin
101	Pump casing	681	Coupling guard
108.01/.02/.04/.05	Stage casing	800	Motor
131	Inlet ring	862	Coupling shell
160	Cover	89-11.03/.08	Retaining bracket
210	Shaft	890.03	Baseplate
230	Impeller	901.02/.05	Hexagon head bolt
341	Drive lantern	903.01/.02	Screw plug
412.01/.03/.04/.06/.07	O-ring	905	Tie bolt
433	Mechanical seal	914.01/.03/.05	Hexagon socket head cap screw

Part No.	Description	Part No.	Description
471	Seal cover	920.01/.02/.03/.05	Nut
525.01/.03/.04/.05	Spacer sleeve	930	Safety device
529	Bearing sleeve	932	Circlip
554.01/.02/.05	Washer	950	Spring

### 9.1.2 Motor

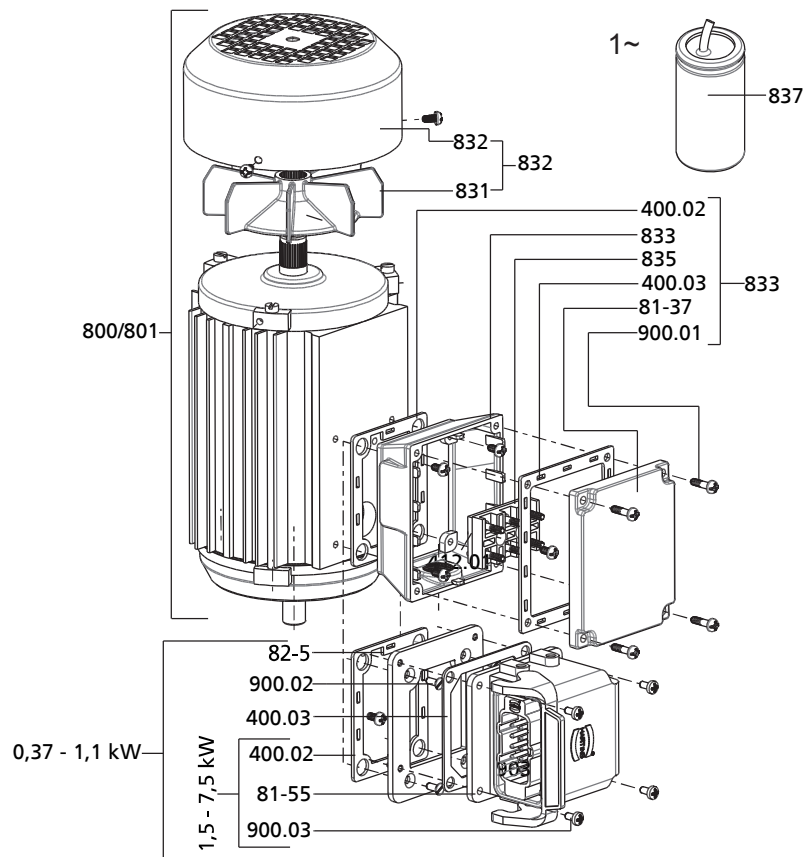

Fig. 22: Exploded view of motor

Table 16: List of components

Part No.	Description	Part No.	Description
400	Gasket	831	Fan impeller
800	Motor	832	Fan hood
801	Flanged motor	833	Terminal box
81-37	Terminal box cover	835	Terminal board
81-55	Socket	837	Capacitor
82-5	Adapter	900	Screw

## 9.2 Wiring diagram

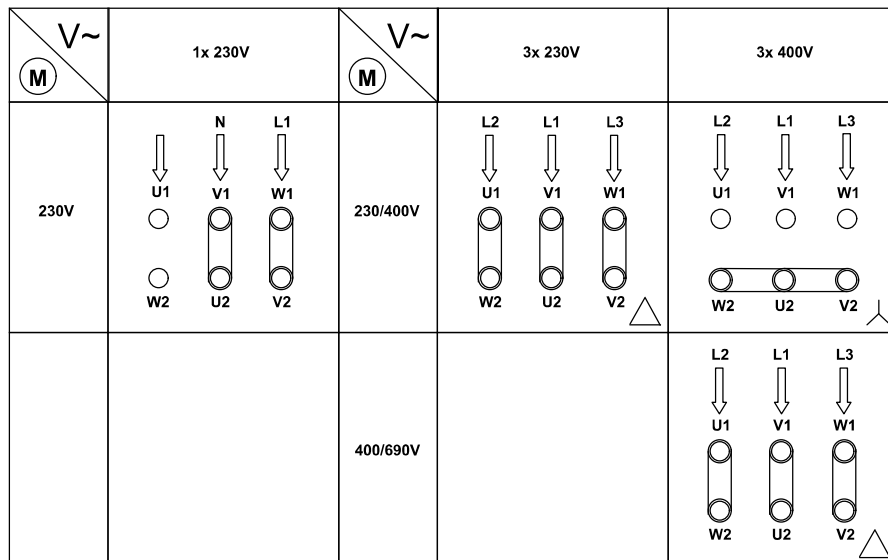

Fig. 23: Wiring diagram, depending on selected motor

---

# 10 EU Declaration of Conformity

Manufacturer:

**D.P. Industries B.V.**  
Kalkovenweg 13  
2401 LJ Alphen aan den Rijn (The Netherlands)

The manufacturer herewith declares that **the product**:

## **DPH(S)I**

**Serial numbers:** 06/2017 1000000-001 - 52/2018 9999999-999

- is in conformity with the provisions of the following Directives as amended from time to time:
  - Pump (set): EC Machinery Directive 2006/42/EC

The manufacturer also declares that

- the following harmonised international standards have been applied:
  - ISO 12100:2010
  - EN 809: 1998+A1:2009/AC:2010

Person authorised to compile the technical file:

Menno Schaap  
Manager Product Development  
D.P. Industries B.V.  
Kalkovenweg 13  
2401 LJ Alphen aan den Rijn (The Netherlands)

The EU Declaration of Conformity was issued in/on:

Alphen aan den Rijn, 1 June 2017



Menno Schaap  
Manager Product Development  
D.P. Industries B.V.  
2401 LJ Alphen aan den Rijn

# 11 Certificate of Decontamination

Type: .....  
Order number/ .....  
Order item number<sup>13)</sup>: .....  
Delivery date: .....  
Field of application: .....  
Fluid handled<sup>13)</sup>: .....

Please tick where applicable<sup>13)</sup>:



Radioactive



Explosive



Corrosive



Toxic



Harmful



Bio-hazardous



Highly flammable



Safe

Reason for return<sup>13)</sup>: .....

Comments: .....

.....

The product/accessories have been carefully drained, cleaned and decontaminated inside and outside prior to dispatch/ placing at your disposal.

We herewith declare that this product is free from hazardous chemicals, biological and radioactive substances.

For mag-drive pumps, the inner rotor unit (impeller, casing cover, bearing ring carrier, plain bearing, inner rotor) has been removed from the pump and cleaned. In cases of containment shroud leakage, the outer rotor, bearing bracket lantern, leakage barrier and bearing bracket or adapter have also been cleaned.

For canned motor pumps, the rotor and plain bearing have been removed from the pump for cleaning. In cases of leakage at the stator can, the stator space has been examined for fluid leakage; if fluid handled has penetrated the stator space, it has been removed.

- No special safety precautions are required for further handling.
- The following safety precautions are required for flushing fluids, fluid residues and disposal:

.....  
.....

We confirm that the above data and information are correct and complete and that dispatch is effected in accordance with the relevant legal provisions.

.....  
Place, date and signature

.....  
Address

.....  
Company stamp

13) Required fields

---

# Index

## A

Applications 8

## B

Bearings 16

## C

Certificate of decontamination 53

Commissioning/start-up 25

Configuration 16

## D

Design 15

Designation 14

Direction of rotation 23

Dismantling 36

Disposal 13

Drive 16

## E

Electrical connection 22

Event of damage

Ordering spare parts 46

Explosion protection 21, 32, 34

## F

Faults

Causes and remedies 47

Function 16

## G

Grease lubrication

Grease quality 34

Intervals 34

## I

Installation 15, 36

Installation on a foundation 18

Installation at site 18

Intended use 8

## K

Key to safety symbols/markings 8

## M

Maintenance 33

Misuse 9

## N

Name plate 15

## O

Other applicable documents 6

## P

Partly completed machinery 6

Permissible forces at the pump nozzles 21

Piping 20

Preservation 12, 31

Product description 14

## R

Return to supplier 13

Returning to service 31

## S

Safety 8

Safety awareness 10

Scope of supply 17

Shaft seal 16

Shutdown 31

Spare part

Ordering spare parts 46

Storage 12, 31

## T

Tightening torques 46

Transport 11

## W

Warnings 8



---

## **dp pumps**

**dp pumps**  
P.O. Box 28  
2400 AA Alphen aan den Rijn  
The Netherlands

**t** +31 172 48 83 88  
**f** +31 172 46 89 30

[dp@dp-pumps.com](mailto:dp@dp-pumps.com)  
[www.dp-pumps.com](http://www.dp-pumps.com)

12/2017

BE00000656 / EN (1798.8560/01)  
Can be changed without prior notice  
Original instructions

